

Induction Heating Coils Design and Basic

In a sense, coil design for [induction heating](#) is built upon a large store of empirical data whose development springs from several simple inductor geometries such as the solenoid coil. Because of this, coil design is generally based on experience. This series of articles reviews the fundamental electrical considerations in the design of inductors and describes some of the most common coils in use.

Basic design considerations

The inductor is similar to a transformer primary, and the workpiece is equivalent to the transformer secondary (**Fig. 1**). Therefore, several of the characteristics of transformers are useful in the development of guidelines for coil design.

One of the most important features of transformers is the fact that the efficiency of coupling between the windings is inversely proportional to the square of the distance between them. In addition, the current in the primary of the transformer, multiplied by the number of primary turns, is equal to the current in the secondary, multiplied by the number of secondary turns. Because of these relationships, there are several conditions that should be kept in mind when designing any coil for induction heating:

1) The coil should be coupled to the part as closely as feasible for maximum energy transfer. It is desirable that the largest possible number of magnetic flux lines intersect the workpiece at the area to be heated. The denser the flux at this point, the higher will be the current generated in the part.

2) The greatest number of flux lines in a solenoid coil are toward the center of the coil. The flux lines are concentrated inside the coil, providing the maximum heating rate there.

3) Because the flux is most concentrated close to the coil turns themselves and decreases farther from

them, the geometric center of the coil is a weak flux path. Thus, if a part were to be placed off center in a coil, the area closer to the coil turns would intersect a greater number of flux lines and would therefore be heated at a higher rate, whereas the area of the part with less coupling would be heated at a lower rate; the resulting pattern is shown schematically in **Fig. 2**. This effect is more pronounced in high-frequency induction heating.

4) At the point where the leads and coil join, the magnetic field is weaker; therefore, the magnetic center of the inductor is not necessarily the geometric center. This effect is most apparent in single-turn coils. As the number of coil turns increases and the flux from each turn is added to that from the previous turns, this condition becomes less important. Due to the impracticability of always centering the part in the work coil, the part should be offset slightly toward this area. In addition, the part should be rotated, if practical, to provide uniform exposure.

5) The coil must be designed to prevent cancellation of the magnetic field. The coil on the left in **Fig. 3** has no inductance because the opposite sides of the inductor are too close to each other. Putting a loop in the inductor (coil at center) will provide some inductance. The coil will then heat a conducting material inserted in the opening. The design at the right provides added inductance and is more representative of good coil design.

Because of the above principles, some coils can transfer power more readily to a load because of their ability to concentrate magnetic flux in the area to be heated. For example, three coils that provide a range of heating behaviors are:

- a helical solenoid, with the part or area to be heated located within the coil and, thus, in the area of greatest magnetic flux;

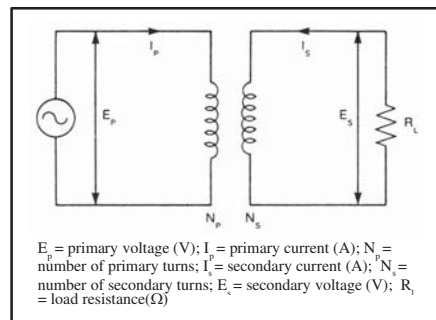

Fig. 1: Electrical circuit illustrating the analogy between induction heating and the transformer principle.

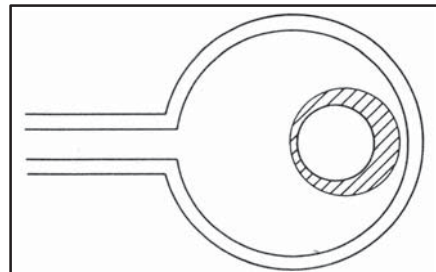

Fig. 2: Induction heating pattern produced in a round bar placed off center in a round induction coil.

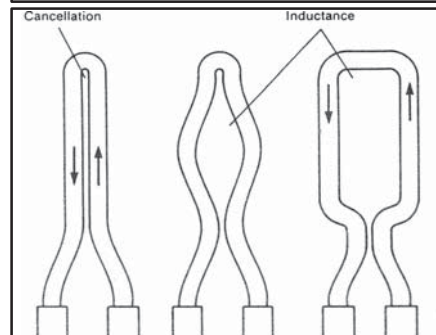

Fig. 3: Effect of coil design on Inductance (from F. W. Curtis, *High Frequency Induction Heating*, McGraw-Hill, New York, 1950)

- a pancake coil, with which the flux from only one surface intersects the workpiece; and
- an internal coil for bore heating, in which case only the flux on the outside of the coil is utilized.

In general, helical coils used to heat round workpieces have the highest values of coil efficiency and internal coils have the lowest values (Table I). Coil efficiency is that part of the energy delivered to the coil that is transferred to the workpiece. This should not be confused with overall system efficiency.

Besides coil efficiency, heating pattern, part motion relative to the coil, and production rate are also important. Because the heating pattern reflects the coil geometry, inductor shape is probably the most important of these factors. Quite often, the method by which the part is moved into or out of the coil can necessitate large modifications of the optimum design. The type of power supply and the production rate must also be kept in mind. If one part is needed every 30 seconds but a 50-second heating time is required, it will be necessary to heat parts in multiples to meet the desired production rate. Keeping these needs in mind, it is important to look at a wide range of coil techniques to find the most appropriate one.

Medium-to-high-frequency

Simple solenoid coils are often relied on in medium-to-high-frequency applications such as heat treatment. These include single- and multiple-turn types. Fig. 4 illustrates a few of the more common types based on the solenoid design. Fig. 4a is a multiturn, single-place coil, so called because it is generally used for heating a single part at a time. A single-turn, single-place coil is also illustrated (Fig. 4b). Fig. 4c shows a single-turn, multiplace coil. In this design, a single turn interacts with the workpiece at each part-heating location. Fig. 4(d) shows a multiturn, multiplace coil.

More often than not, medium-to-high-frequency applications require specially configured or contoured coils with the coupling adjusted for heat uniformity. In the simplest cases, coils are bent or formed to the contours of the part (Fig. 5). They may be round (Fig. 5a), rectangular (Fig. 5b), or formed to meet a specific shape such as the cam coil (Fig.

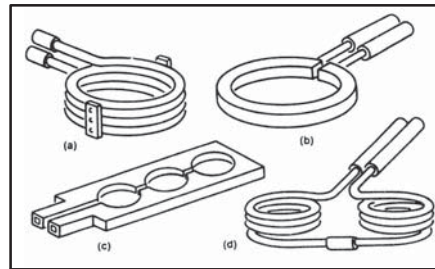

Fig. 4: Typical configurations for induction coils: (a) multiturn, single place; (b) single-turn, single place; (c) single-turn, multiplace (from F. W. Curtis, *High Frequency Induction Heating*, McGraw-Hill, New York, 1950)

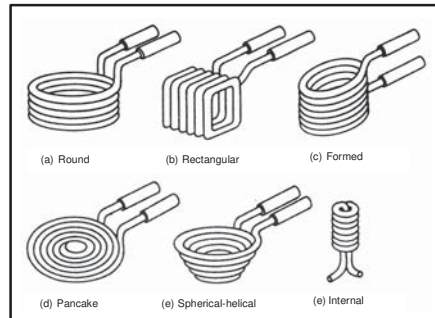

Fig. 5: Multiturn coils designed for heating parts of various shapes: (a) round; (b) rectangular; (c) formed; (d) pancake; (e) spiral-helical; (f) internal (from F. W. Curtis, *High Frequency Induction Heating*, McGraw-Hill, New York, 1950)

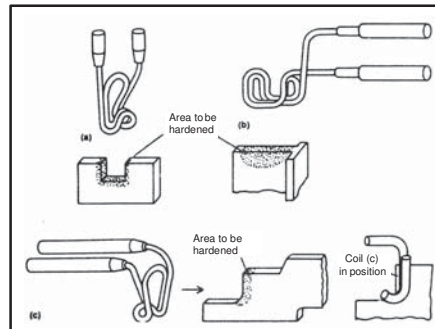

Fig. 6: Coil modifications for localized heating (from F. W. Curtis, *High Frequency Induction Heating*, McGraw-Hill, New York, 1950)

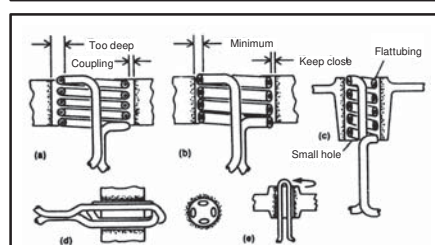

Fig. 7: Induction coils designed for internal (bore) heating (from F. W. Curtis, *High Frequency Induction Heating*, McGraw-Hill, New York, 1950)

5c). Pancake coils (Fig. 5d) are generally utilized when it is necessary to heat from one side only or when it is not possible to surround the part. Spiral coils (Fig. 5e) are generally used for heating bevel gears or tapered punches. Internal bores can be heated in some cases with multiturn inductors (Fig. 5f). It is important to note that, with the exception of the pancake and internal coils, the heated part is always in the center of the flux field.

Regardless of the part contour, the most efficient coils are essentially modifications of the standard, round coil. A conveyor or channel coil, for example, can be looked at as a rectangular coil whose ends are bent to form “bridges” in order to permit parts to pass through on a continuous basis. The parts, however, always remain “inside” the channels where the flux is concentrated. Fig. 6 illustrates similar situations in which the areas to be hardened are beside the center of the coil turns, and thus are kept in the area of heaviest flux.

Internal coils

Heating of internal bores, whether for hardening, tempering, or shrink fitting, is one of the major problems most commonly confronted. For all practical purposes, a bore with a 0.44-inch (1.1-cm) internal diameter is the smallest that can be heated with a 450-kHz power supply. At 10 kHz, the practical minimum ID is 1.0 inch (2.5-cm).

Tubing for internal coils should be made as thin as possible, and the bore should be located as close to the surface of the coil as is feasible. Because the current in the coil travels on the inside of the inductor, the true coupling of the maximum flux is from the ID of the coil to the bore of the part. Thus, the conductor cross section should be minimal, and the distance from the coil OD to the part (at 450 kHz) should approach 0.062-inch (0.16-cm). In Fig. 7a, for example, the coupling distance is too great; coil modification improves the design, as shown in Fig. 7b. Here, the coil tubing has been flattened to reduce the coupling distance, and the coil OD has been increased to reduce the spacing from coil to work.

More turns, or a finer pitch on an internal coil, will also increase the flux density. Accordingly, the space between the turns should be no more than one-half the diameter of the tubing, and the overall height of the coil should not

Coil design

exceed twice its diameter. **Figs. 7c and 7d** show special coil designs for heating internal bores. The coil in Fig. 7d would normally produce a pattern of four vertical bands, and therefore the part should be rotated for uniformity of heating.

Internal coils, of necessity, utilize very small tubing or require restricted cooling paths. Further, due to their comparatively low efficiency, they may need very high generator power to produce shallow heating depths.

Coil characterization

Because magnetic flux tends to concentrate toward the center of the length of a solenoid work coil, the heating rate produced in this area is generally greater than that produced toward the ends. Further, if the part being heated is long, conduction and radiation remove heat from the ends at a greater rate. To achieve uniform heating along the part length, the coil must thus be modified to provide better uniformity. The technique of adjusting the coil turns, spacing, or coupling with the workpiece to achieve a uniform heating pattern is sometimes known as “characterizing” the coil.

There are several ways to modify the flux field. The coil can be decoupled in its center, increasing the distance from the part and reducing the flux in this area. Secondly, and more commonly, the number of turns in the center (turn density) can be reduced, producing the same effect. A similar approach - altering a solid single-turn inductor by increasing its bore diameter at the center - achieves the same result.

In **Fig. 8a**, the coil turns have been modified to produce an even heating pattern on a tapered shaft. The closer turn spacing toward the end compen-

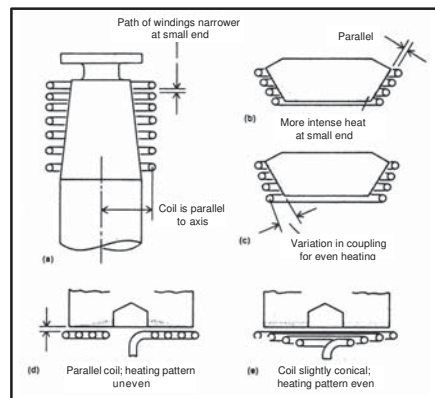

Fig. 8: Adjustment (“characterization”) of induction heating patterns for several parts by varying the coupling distance or turn spacing (from F. W. Curtis, *High Frequency Induction Heating*, McGraw-Hill, New York, 1950)

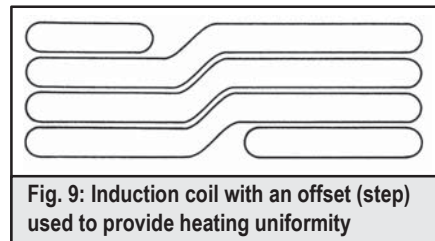

Fig. 9: Induction coil with an offset (step) used to provide heating uniformity

sates for the decrease in coupling caused by the taper. This technique also permits “through the coil” loading or unloading to facilitate fixturing. A similar requirement in the heat treatment of a bevel gear is shown in Fig. 8b. Here, because of the greater part taper, a spiral-helical coil is used. With a pancake coil, decoupling of the center turns provides a similar approach for uniformity.

Multiturn vs. single-turn

Heating-pattern uniformity requirements and workpiece length are the two main considerations with regard to the selection of a multiturn vs. a single turn induction coil. A fine-pitch, multiturn coil closely coupled to the workpiece develops a very uniform heating pattern. Similar uniformity can

be achieved by opening up the coupling between the part and the coil so that the magnetic flux pattern intersecting the heated area is more uniform. However, this also decreases energy transfer. Where low heating rates are required, as in through heating for forging, this is acceptable. When high heating rates are needed, however, it is sometimes necessary to maintain close coupling. The pitch of the coil must be opened to prevent overloading of the generator.

Because the heating pattern is a mirror image of the coil, the high flux field adjacent to the coil turns will produce a spiral pattern on the part. This is called “barber poling,” and can be eliminated by rotating the workpiece during heating. For most hardening operations, which are of short duration, rotational speeds producing *not less than 10* revolutions during the heating cycle should be used.

If part rotation is not feasible, heating uniformity can be increased by using flattened tubing, by putting a step in the coil, or by attaching a liner to the coil. Flattened tubing should be placed so that its larger dimension is adjacent to the workpiece. The stepping of coil turns (**Fig. 9**) provides an even, horizontal heating pattern. Stepping is easily accomplished by annealing the coil after winding and pressing it between two boards in a vise. A coil liner is a sheet of copper soldered or brazed to the inside face of the coil. This liner expands the area over which the current travels. Thus, a wide field per turn can be created. The height of this field can be modified to suit the application by controlling the dimensions of the liner. When a liner is used, the current path from the power supply passes through the connecting tubing (**Fig.10**). Between the two connections, the tubing is used solely for conduction cooling of the liner.

In fabricating coils with liners, it is necessary only to tack-braze the tubing to the liner at the first and last connection points, with further tacks being used solely for mechanical strength. The remainder of the common surfaces between tubing and liner can then be filled with a low temperature solder for maximum heat conduction, because the coil-water temperature will never exceed the boiling point of water, which is well below the flow point of the solder. This may be necessary because the copper may be unable to conduct heat fast

Coupling efficiency at frequency of:	10 Hz		450 kHz	
	Magnetic steel	Other metals	Magnetic steel	Other metals
Type of coil				
Helical around workpiece	0.75	0.50	0.80	0.60
Pancake	0.35	0.25	0.50	0.30
Hairpin	0.45	0.30	0.60	0.40
One turn around workpiece	0.60	0.40	0.70	0.50
Channel	0.65	0.45	0.70	0.50
Internal	0.40	0.20	0.50	0.25

Table 1: Typical coupling efficiencies for induction coils

enough from the inside of the coil.

In multiturn coils, as the heated length increases, the number of turns generally should increase in proportion. In **Fig. 11a**, the face width of the coil is in proportion to the coil diameter. In **Fig. 11b**, the ratio of the coil diameter to face width is not suitable; the multiturn coil shown in **Fig. 11c** provides a more acceptable heat pattern. Multiturn coils of this type are generally utilized for large-diameter, single-shot heating, in which the quench medium can be sprayed between the coil turns (**Fig. 11d**).

When the length of the coil exceeds four to eight times its diameter, uniform heating at high power densities becomes difficult. In these instances, single-turn or multiturn coils that scan the length of the workpiece are often preferable. Multiturn coils generally improve the efficiency, and therefore the scanning rate, when a power source of a given rating is used. Single-turn coils are also effective for heating bands that are narrow with respect to the part diameter.

The relationship between diameter and optimum height of a single-turn coil varies somewhat with size. A small coil can be made with a height equal to its diameter because the current is concentrated in a comparatively small area. With a larger coil, the height should not exceed one-half the diameter. As the coil opening increases, the ratio is reduced — i.e., a 2-inch (5.1-cm) ID coil should have a 0.75-inch (1.91-cm) maximum height, and a 4-inch (10.2-cm) ID coil should have a 1.0-inch (2.5-cm) height. **Fig. 12** shows some typical ratios.

Coupling distance

Preferred coupling distance depends on the type of heating (single-shot or scanning) and the type of material (ferrous or nonferrous). In static surface heating, in which the part can be rotated but is not moved through the coil, a coupling distance of 0.060 inch (0.15 cm) from part to coil is recommended. For progressive heating or scanning, a coupling distance of 0.075 inch (0.19 cm) is usually necessary to allow for variations in workpiece straightness. For through heating of magnetic materials, multiturn inductors and slow power transfer are utilized. Coupling distances can be looser in these cases — on the order of 0.25 to 0.38 inch (0.64 to 0.95 cm). It is impor-

tant to remember, however, that process conditions and handling dictate coupling. If parts are not straight, coupling must decrease. At high frequencies, coil currents are lower and coupling must be

increased. With low and medium frequencies, coil currents are considerably higher and decreased coupling can provide mechanical handling advantages. In general, where automated systems are used, coil coupling should be looser.

The coupling distances given above are primarily for heat treating applications in which close coupling is required. In most cases, the distance increases with the diameter of the part, typical values being 0.75, 1.25, and 1.75 inches (19, 32 and 44 mm) or billet-stock diameters of approximately 1.5, 4 and 6 inches (38, 102, and 152 mm), respectively.

Effects of part irregularities

With all coils, flux patterns are affected by changes in the cross-section or mass of the part. As shown in **Fig. 13** (p. 36), when the coil extends over the end of a shaft-like part, a deeper pattern is produced on the end. To reduce this effect, the coil must be brought to a point even with or slightly lower than the end of the shaft. The same condition exists in heating of a disk or a wheel. The depth of heating will be greater at the ends than in the middle if the coil overlaps the part. The coil can be shortened, or the diameter at the ends of the coil can be made greater than at the middle, thereby reducing the coupling at the former location.

Just as flux tends to couple heat to a greater depth at the end of a shaft, it will do the same at holes, long slots, or projections (**Fig. 14**, p. 36). If the part contains a circular hole, an additional eddy-current path is produced that will cause heating at a rate considerably higher than that in the rest of the part. The addition of a copper slug to the hole can effectively correct or eliminate this problem. The position of the slug (**Fig. 15**, p. 36) can control the resultant heating pattern. In addition, the slug will minimize hole distortion if the part must be quenched following heating.

For slotted parts heated with solenoid coils (**Fig. 16**, p. 36), the continuous current path is interrupted by the slot, and the current must then travel on the inside of the part to provide a closed circuit. This is the basis for concentrator coils. It is of interest to note, however, that with the slot closed, the applied voltage of the work coil causes a higher current to flow. This is due to the fact that

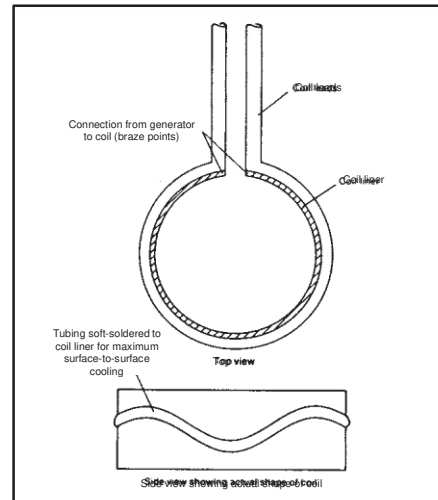

Fig. 10: Method of inserting a liner in a coil to widen the flux path

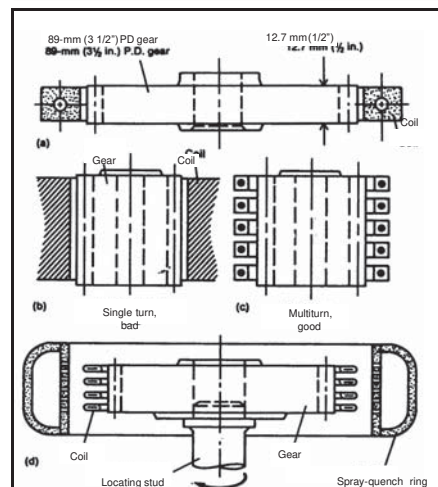

Fig. 11: Selection of single-turn vs. multiturn coils depending on the length-to-diameter ratio of the workpiece (from F. W. Curtis, *High Frequency Induction Heating*, McGraw-Hill, New York, 1950)

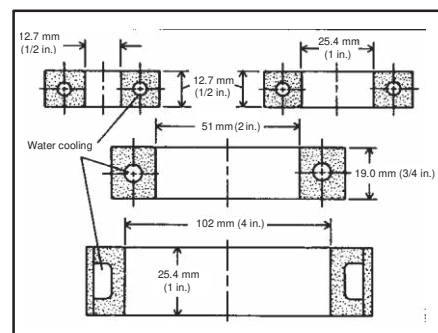

Fig. 12: Typical proportions of various single-turn coils (from F. W. Curtis, *High Frequency Induction Heating*, McGraw-Hill, New York, 1950)

Coil design

the resistive path, now around the periphery of the part, is considerably shorter. The increase in current then produces a considerably higher heating rate

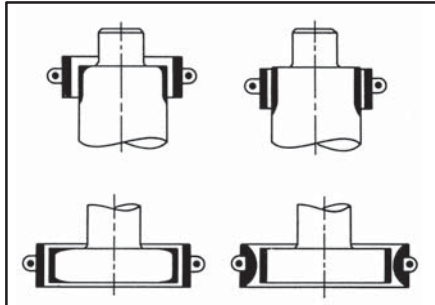

Fig. 13: Effect of coil placement on the heating pattern at the end of a workpiece (from F. W. Curtis, *High Frequency Induction Heating*, McGraw-Hill, New York, 1950)

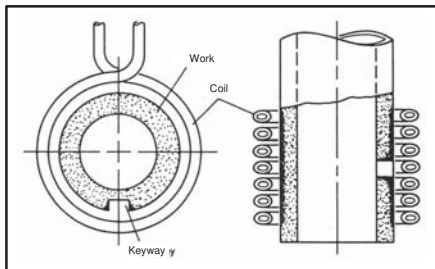

Fig. 14: Localized overheating of sharp corners, keyways, and holes most prevalent in high frequency induction heating (from F. W. Curtis, *High Frequency Induction Heating*, McGraw-Hill, New York, 1950)

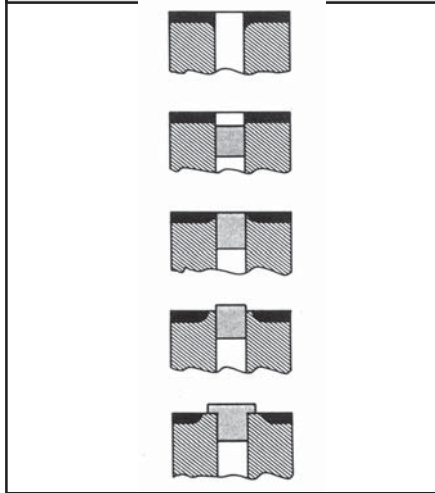

Fig. 15: Control of the heating pattern at a hole through use of copper slugs (from M. G. Lozinski, *Industrial Applications of Induction Heating*, Pergamon Press, London, 1969)

with the same coil.

Flux diverters

When two separate regions of a workpiece are to be heated, but are close together (Fig. 17), it is possible that the magnetic fields of adjacent coil turns will overlap, causing the entire bar to be heated. To avoid this problem, successive turns can be wound in opposite directions. By this means, the intermediate fields will cancel, and the fields that remain will be restricted. It should be noted that, as shown in Fig. 17, lead placement is critical. Having the return inductor spaced far from the coil leads would add unneeded losses to the system. Another example of a counterwound coil is shown in Fig. 18; the coil in Fig. 18b is the counterwound version of the one in Fig. 18a. This type of coil can be used effectively in an application in which the rim of a container is to be heated while the center remains relatively cool.

Another technique that can be utilized in the above circumstances involves the construction of a shorted turn or “robber” placed between the active coil turns. In this case, the shorted loop acts as an easy alternative path for concentration of the excess flux, absorbing the stray field. It is therefore sometimes called a flux diverter. As for the active coil turns, the robber must be water cooled to dissipate its own heat. A typical construction is shown in Fig. 19.

Shorted coil turns are also used effectively to prevent stray-field heating on very large coils where the end flux field might heat structural frames.

Flux robbers or flux diverters can also be used in fabricating test coils when it is desired to determine the optimum number of turns empirically. In these situations, a few additional turns are provided that can be added or removed as required. These can be shorted with a copper strap or temporarily brazed while tests are made and removed pending the outcome of the heating trials.

This is the first installment of a three-part article on coil design and fabrication. Part two, on specialty coils, will appear in August. Part three, on fabrication, will appear in October.

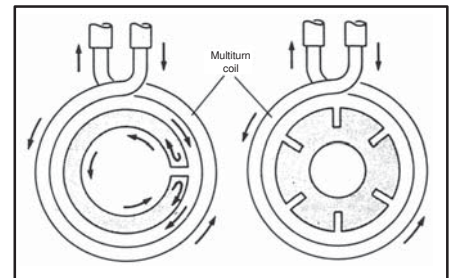

Fig. 16: Localized overheating of slots in certain parts that results from the tendency for induced currents to follow the part contour (from F. W. Curtis, *High Frequency Induction Heating*, McGraw-Hill, New York, 1950)

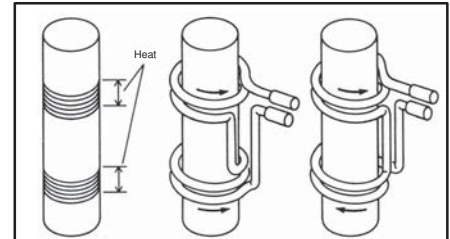

Fig. 17: Control of heating patterns in two different regions of a workpiece by winding the turns in opposite directions (from F. W. Curtis, *High Frequency Induction Heating*, McGraw-Hill, New York, 1950)

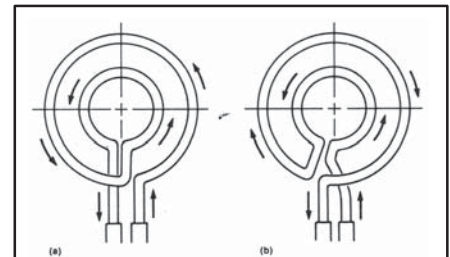

Fig. 18: Design of pancake coils to provide (a) uniform, or overall, heating or (b) peripheral heating only (from F. W. Curtis, *High Frequency Induction Heating*, McGraw-Hill, New York, 1950)

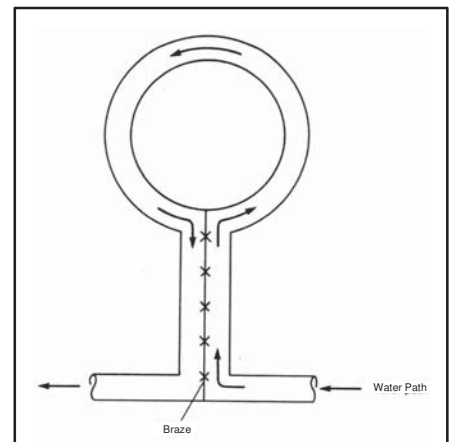

Fig. 19: Typical construction of a water-cooled flux robber.

Coil design and fabrication: part 2, specialty coils

Coil designs are based on the heating-pattern requirements of the application, the frequency, and the power-density requirements. In addition, the material-handling techniques to be used for production determine, to a large extent, the coil to be used. If a part is to be inserted in a coil, moved on a conveyor, or pushed end to end, or if the coil/heat station combination is to move onto the part, the coil design must take the appropriate handling requirements into consideration. Accordingly, a variety of specialty coil designs have evolved for specific applications.

Master work coils and coil insert

When production requirements necessitate small batches (as in job-shop applications) and a single-turn coil can be used, master work coils provide a simple, rapid means of changing coil diameters or shapes to match a variety of parts. In its basic form, a master work coil consists of copper tubing that provides both an electrical connection to the power supply and a water-cooled contact surface for connection to a coil insert (N. B. Stevens and P.R. Capalongo, "Inductor for High-Frequency Induction Heating," U.S. Patent 2,456,091, December 14, 1948). A typical design, shown in Fig. 1, consists of a copper tube that is bent into the form of a single-turn coil and soldered to a copper band that conforms to the slope of the coil insert

S. Zinn is executive vice president, Ameritherm, Inc., Rochester, N.Y.; (716) 427-7840. S.L. Semiatin is a project manager in the Center for Materials Fabrication at Battelle Columbus Division; (614) 424-7742.

This article is excerpted from the book "Elements of Induction Heating," published by Electric Power Research Institute (EPRI) and distributed by ASM International, (516) 338-5151 and used with permission of EPRI.

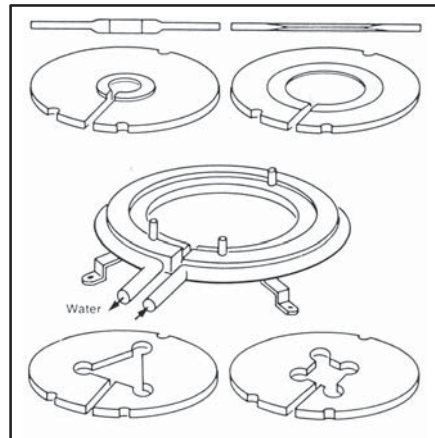

Fig. 1: Schematic illustration showing the design of a master coil with changeable inserts (from M.G. Lozinski, *Industrial Applications of Induction Heating*, Pergamon Press, London, 1969)

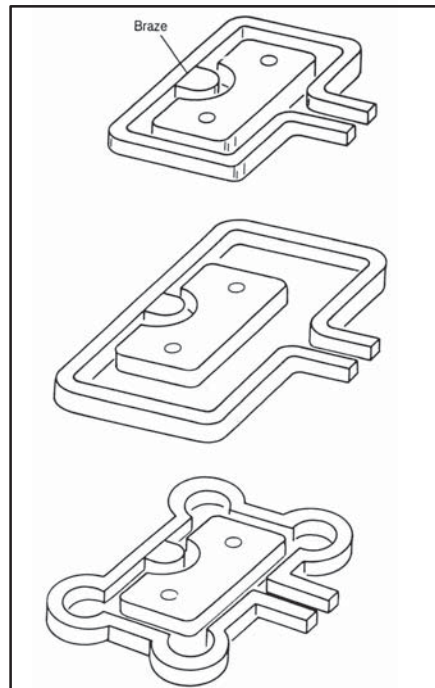

Fig. 2: Inductor with a relief designed for the hardening of the lateral surface of a template (from M.G. Lozinski, *Industrial Applications of Induction Heating*, Pergamon Press, London, 1969)

and is recessed. Holes in the inserts that match tapped holes in the master coil securely clamp the inserts to the master coil, providing good transfer of electrical energy and heat removal. Inserts are machined from copper with a thickness that matches the required heating pattern, and should be somewhat greater in thickness than the depth of the recess for easy removal. Special coil shapes are easily configured. It is important to note that, because of the less-than-optimal cooling technique, coil inserts are particularly well adapted to processes requiring short heating times or those in which they are also cooled by the quenching medium.

In machining of coil inserts, care must be taken to relieve sharp corners, unless it is desired to have a deeper heating pattern in these locations. Fig. 2 shows the effect of sharp corners on a closely coupled part. Flux from both inductor sides couples to the corner, which, due to a lack of mass, tends to overheat relative to the rest of the pattern. Decoupling of the coil from these locations provides the desired pattern but tends to reduce overall efficiency, thus slowing the heating rate and resulting in a deeper case. Relieving or decoupling of only the corners is a better alternative, particularly when a solid, inductor is used, and the relief can be machined as required.

Coils for induction scanners

Coils for progressive hardening (scanning) are built using two techniques. The simpler of the two employs a simple single-turn or multiturn coil with a separate quench ring that can be mounted on the scanner (Fig. 3a, p.30). For larger production runs, a double chamber coil that incorporates

Specialty coils

both coil cooling and quenching capabilities is often the preferred choice. The scanning inductor shown in **Fig. 3b** is typical of the latter type of design. Cooling water flows through the upper, or inductor, chamber to keep the copper resistivity low. The quenchant is sprayed from perforations in the beveled face onto the workpiece as it exits from the inductor. The beveled face normally is at an angle of 300 to the vertical, so that there is some soaking time between the end of induction heating and the quenching operation. This delay time helps to increase uniformity. Proper choice of the spray direction also reduces the amount of fluid runback on the shaft, which could cause variation in bar temperature and result in uneven hardness. Well-directed quench

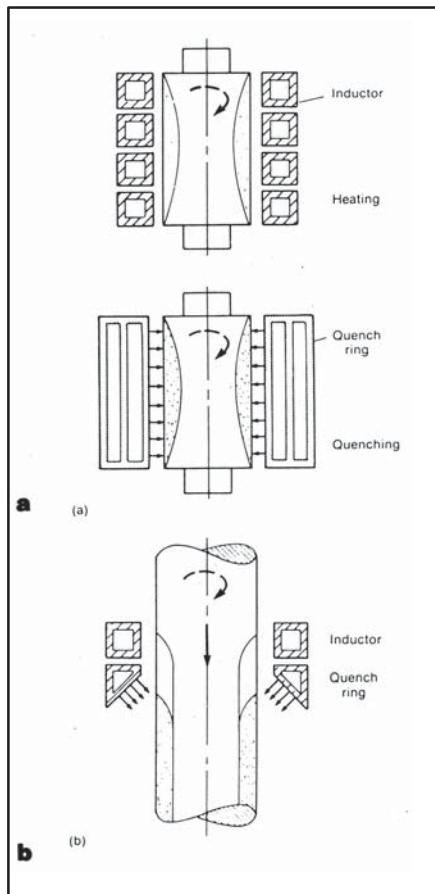

Fig. 3: Inductor/quench designs for induction scanning: (a) separate coil and quench; and (b) two-chamber, integral coil and quench (from F.H. Reinke and W. H. Gowan, *Heat Treatment of Metals*, Vol. 5, No. 2, 1978, p. 39)

spray holes are required inasmuch as "barber poling" can occur due to erratic or misdirected quenchant that pre-cools the part ahead of the main quench stream.

Split coils

Split coils are generally utilized as a last resort for applications in which it is difficult to provide a high enough power density to the area to be heated without very close coupling, and where part insertion or removal would then become impossible. One such situation is the hardening of journals and shoulders in crankshafts. In this case, the split-coil design would also include the ability to quench through the face of the inductor. Typical methods of hinging split inductors are shown in **Fig. 4**.

It should be noted that with a split inductor, good surface-to-surface contact must be made between the

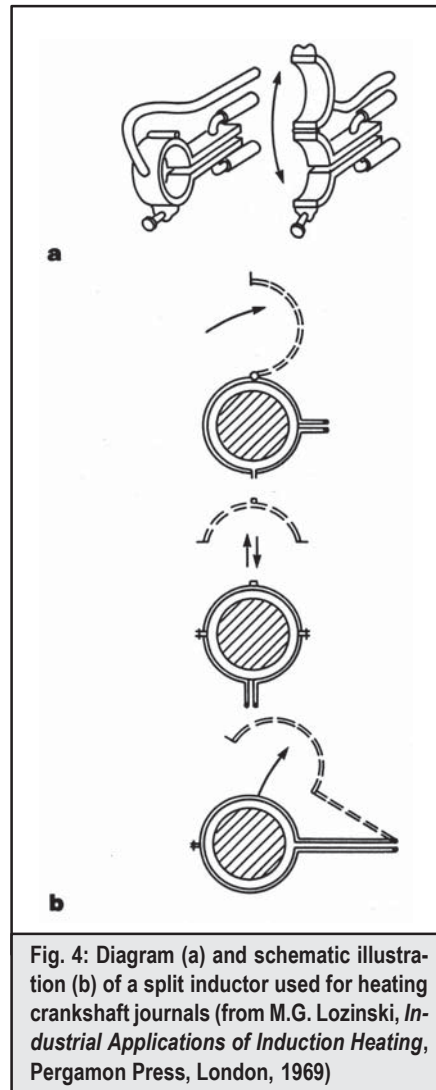

Fig. 4: Diagram (a) and schematic illustration (b) of a split inductor used for heating crankshaft journals (from M.G. Lozinski, *Industrial Applications of Induction Heating*, Pergamon Press, London, 1969)

faces of the hinged and fixed portions of the coil. Generally, these surfaces are faced with silver or special alloy contacts that are matched to provide good surface contact. Clamps are used to ensure closure during heating. High currents at high frequency pass through this interface, and the life of the contact is generally limited due to both wear and arcing.

Coolant for the coil chamber of a split inductor is carried by flexible hoses that bypass the hinge so that excessive heating does not occur in the movable section during the cycle. The quench chamber is fed by a separate hose arrangement. The face of the quench chamber is closest to the work during heating, and therefore carries most of the current. Accordingly, it must be sufficiently thick to preclude either melting or distortion during the heating cycle.

With split coils it is also frequently necessary to provide some means of locating the part in the coil to maintain the proper coupling distance. Ceramic pins or buttons are frequently secured to the face of the inductor. These pins contact the part during the heating cycle and establish rigid relative positioning between part and coil. However, they are subject to thermal shock during the heating and quenching cycles and suffer mechanical abuse as well. Therefore, they should be designed for simple replacement as required. **Fig. 5** depicts an arrangement for the use of either ceramic or metal pins that compensates for these problems. Here, the ceramic pin is approximately 0.25 inch (0.64 cm) in diameter and 0.5 inch (1.3 cm) long with a 0.27-inch (0.69) head diameter. The rubber packing absorbs the clamping stress. A threaded tube passes through the chamber, and a screw presses the pins against the shaft. In **Fig. 5b**, a 0.125 inch (0.32 cm) nichrome pin is used with a ceramic tube as an insulator. Being in compression, the tube undergoes comparatively high loads without breaking. The metal pin provides longer life in these conditions than the ceramic pin.

Butterfly coils

One of the most difficult heating chal-

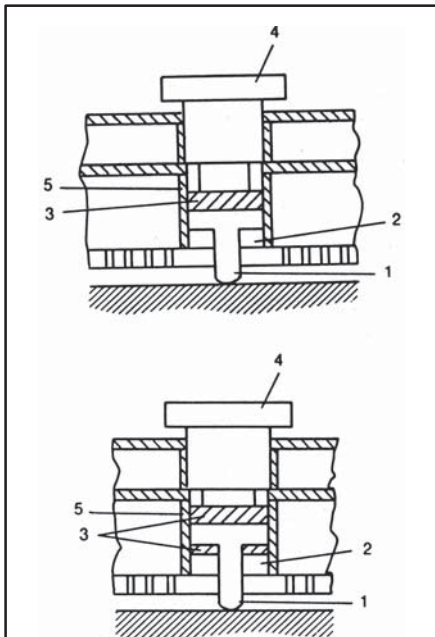

Fig. 5: Design of metal and ceramic pins for fixing the position of a split inductor on a crankshaft journal (from M.G. Lozinski, *Industrial Applications of Induction Heating*, Pergamon Press, London, 1969)

lenges is the creation of an even heating pattern at the end of a bar or shaft. Patterns developed with a pancake inductor produce a dead spot at the center, due to field cancellation in this area.

The butterfly coil (Fig. 6), so named because of its appearance, utilizes two specially formed pancake coils. The current paths of the adjacent sides are aligned so that they are additive. The “wings” of the butterfly may be bent up to decouple their fields from the shaft, or, if heat is required in this location, they may be coupled with the shaft itself. In winding this coil, it is important that all center turns be wound in the same direction so that they are additive. Further, only these turns should couple directly with the part to produce the desired pattern.

Split-return inductors

If a narrow band of heat is required and heating must be accomplished from one surface only, the split-return inductor offers distinct advantages (Fig. 7). With this design, the center runner of the work coil carries twice the current of each of the return legs. The pattern on the workpiece, being a mirror image of the coil, produces four times as much

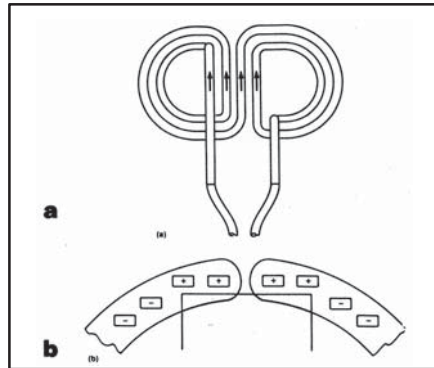

Fig. 6: Schematic illustration of a butterfly coil: (a) coil construction (arrows indicate reinforcing type of current flow in coil); and (b) coupling between the turns of the coil and the end of a bar to produce a uniform heating pattern

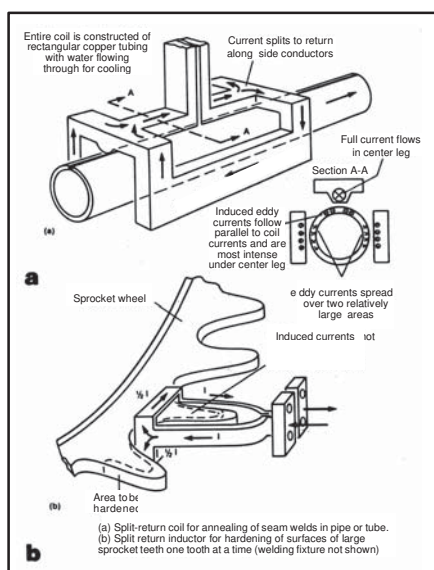

Fig. 7: Two types of split-return coils (from C. A. Tudbury, *Basics of Induction Heating*, Vol. 1, John F. Rider, Inc., New York, 1960)

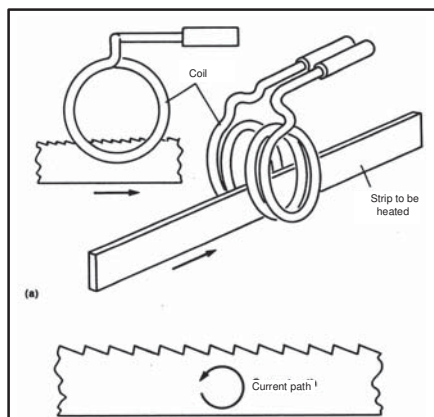

Fig. 8: Illustration (a) of one type of transverse coil for heating a thin section; sketch in (b) indicates the current path in the workpiece (from F. W. Curtis, *High Frequency Induction Heating*, McGraw-Hill, New York, 1950)

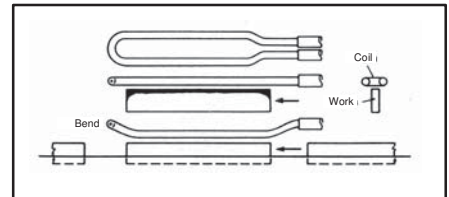

Fig. 9: Typical channel coil used to heat the edges of discrete lengths of rectangular bar stock; end of coil is decoupled by bending to prevent overheating of ends (from F. W. Curtis, *High Frequency Induction Heating*, McGraw-Hill, New York, 1950)

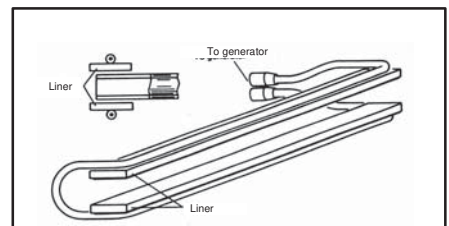

Fig. 10: Use of a liner on a single-turn channel coil to provide a wider heating pattern on the workpiece (from F. W. Curtis, *High Frequency Induction Heating*, McGraw-Hill, New York, 1950)

heat under the center leg as in each of the return loops. With proper balancing, the high-heat path can then be extremely narrow, while the heat produced in each of the return legs is insufficient to affect the remainder of the part.

Tapped coils

Induction coils can be provided with taps to allow for differences in heated length. A typical application is a forging coil for heating “off the end” of a bar, in which provision must be made to adjust the length being heated. Taps are brazed to the work coil at locations where a water-cooled strap can be moved from tap to tap. The active portion of the coil is then between the power-supply connection and the tap. Water cooling, however, should be maintained through all portions of the coil, both active and inactive.

Transverse-flux coils

In heating of parts that have a long longitudinal axis and a thin cross-section, a circular coil wrapped around the workpiece produces a heating pattern (Fig. 8) that, due to coupling distances, is effective only at the edges. In transverse-flux heating, however, the coil is designed to set

Specialty coils

up a flux field that is perpendicular to the sheet or similar part. In this way, the path of the eddy currents is changed so that it is parallel to the major axis of the work. For example, in the manufacture of items such as hacksaw blades, the steel moves between the turns of the coil and the eddy-current path is a circular one across the flat of the blade. For heating of wide sheet materials, specially designed transverse-flux inductors have, in recent years, also become available.

Conveyor/channel coils

Often when power densities are low and heating cycles not extremely short, parts can be processed by use of a turntable or conveyor in a continuous or indexing mode. The coil must then be designed to permit easy entry and exit of the part. The simplest conveyor or channel coil used in these situations is a modification of the hairpin inductor (Fig. 9, p.31). With the indexing technique, in which the part is at rest in the coil during the heating cycle, the ends of the hairpin can be decoupled to prevent overheating of the ends. These raised portions or bridges also facili-

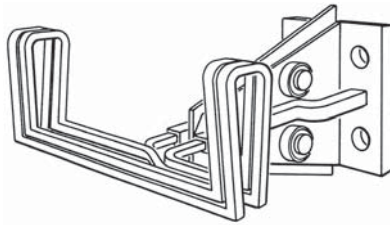

Fig. 11: Multiturn channel coil used to increase the ampere turns coupled to an induction heated workpiece (source: Lindberg Cycle-Dyne Inc.)

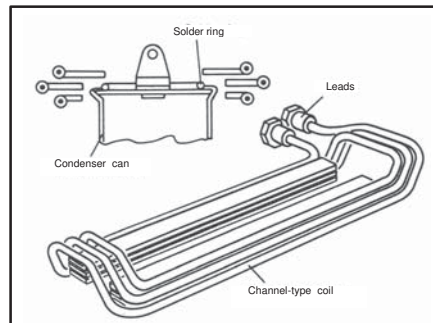

Fig. 12: Multiturn channel coil with a liner added to control the heating pattern (from F.W. Curtis, *High Frequency Induction Heating*, McGraw-Hill, New York, 1950)

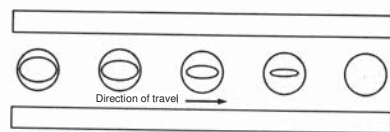

Fig. 13: Development of the heating pattern in parts moved through a channel coil.

tate passage of the part through the coil. When a wide heating zone is to be produced on the part, coupling over a greater area can be accomplished through the addition of a liner to the coil turn (Fig. 10, p. 31), or more ampere turns can also be produced with a multiturn channel inductor (Fig. 11). Channel-coil liners may also be configured to produce specialized heating patterns where greater heat densities are required in specific areas (Fig. 12).

During design of heating operations using channel coils, there is a "fill factor" that must be considered from an efficiency standpoint. The unused portions of the coil appear as lead losses. Therefore, parts must be as close as possible to each other, without touching, to utilize the full capabilities of the inductor. Another important consideration in the use of a channel coil is the fact that those areas of the workpiece closest to the coil receive the greatest portion of the flux and therefore heat the fastest (Fig. 13). If conduction through the part is slow, the part should be rotated while passing through the coil. Sufficient time (in an indexing conveyor or turntable) or speed variation (in a continuous-motion device) must be provided to allow heat uniformity to occur in part areas farthest from the coil turns.

Coil design and fabrication: part 3, fabrication principles

by STANLEY ZINN and S. L. SEMIATIN

Because of its low resistivity, fully annealed, high-conductivity copper is most commonly used in the fabrication of induction heating coils. The copper is typically in a tubular form, with a minimum outer diameter of 0.125 inch (0.32 cm) to allow for water cooling. Material of this kind is available in a wide range of cross sections (round, square, and rectangular) and sizes.

Selection of tubing

In addition to the I^2R loss due to its own resistivity, the coil surrounds the load and absorbs additional heat through radiation and convection from the heated surface. Therefore, it is essential that the tubing selected for the work coil have a sufficient cooling path to remove this heat. Otherwise, the resistivity of the copper will increase due to the temperature increase, thus creating greater coil losses. In some instances, such as large coils, it may be necessary to break up the individual water paths in a coil to prevent overheating and possible coil failure.

Another factor in the selection of tubing for induction coils relates to the fact that the current in the work coils is traveling at a specific reference depth that depends on the power-supply frequency and the resistivity of the copper. Accordingly, the wall thickness of the coil tubing should be selected to reference-depth

S. Zinn is executive vice president, Ameritherm, Inc., Rochester, N.Y.; (716) 427-7840. S.L. Semiatin is a project manager in the Center for Materials Fabrication at Battelle Columbus Division; (614) 424-7742.

This article is excerpted from the book "Elements of Induction Heating," published by Electric Power Research Institute (EPRI) and ASM International and distributed by ASM International, (516) 338-5151 Used with permission of ASM International and EPRI.

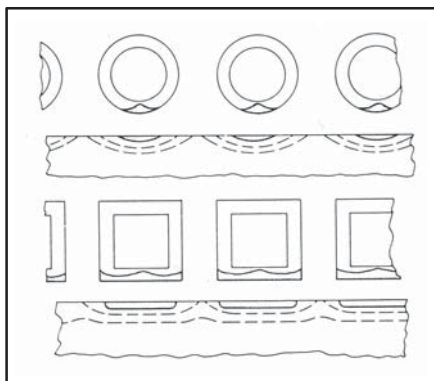

Fig. 1: Comparative heating patterns produced by using round vs. square tubing for a solenoid induction coil (from M. G. Lozinsky, *Industrial Applications of Induction Heating*, Pergamon Press, London, 1969)

limits similar to those used for induction heating of copper. Suggested wall thicknesses for various frequencies are shown in **Table I** (p.40). However, copper availability must be considered, and often wall thicknesses less than twice the reference depth are used with only a nominal loss in overall coil efficiency.

Square copper tubing is also commercially available and is frequently used in coil fabrication. It offers a considerable advantage in that it couples more flux to the part per turn than round tubing (**Fig. 1**). Moreover, it is more easily fabricated in that it will not collapse as readily on bending. It is also easily mitered to create sharp, close bends as required. If only round tubing is available, it can be flattened in a vise or other simple device to adjust the resultant thickness dimension. This flattening can be done with minimal decrease in dimension of the water-flow path.

Coil forming

In fabrication of copper coils, it must be noted that the copper work hardens with increasing deformation. Thus, most fabricators anneal the tubing every few

bends to relieve this condition by heating the tubing until it is bright red, then cooling it rapidly in water. These intermediate anneals prevent fracture of the tubing during fabrication.

In some forming operations, it may be desirable to fill the coil with sand or salt to preclude collapse of the tubing. In addition, there are several low-temperature alloys-with melting points below 212°F (100°C)-that are normally used to perform this same function. When the coil is completed, it is immersed in boiling water. The alloy then flows out freely and can be reused at another time. With any of these techniques, once filled, the tubing acts as a solid rod during forming and can be simply cleared on completion.

Bracing of coils

Because electric currents flow in both the workpiece and the coil, magnetomotive forces between the two are developed. The magnitudes of the forces depend on the magnitudes of the currents. If sufficiently large, the forces may cause the part to move in the coil. If the part has a large mass, however, the coil will tend to move relative to the workpiece. The turns may also tend to move relative to each other. It is important, therefore, that the coil turns be suitably braced to prevent movement and possible turn-to-turn shorting. Furthermore, coil motion relative to the part must be prevented to avoid undesirable changes in the heating pattern.

Much of the acoustic noise generated during low-frequency operations also occurs due to coil vibration, much as a speaker coil and magnet structure work in an audio system. Bracing and physical loading of the coil to restrict its movement will aid in reducing this condition. On very large, high-current coils, the magnetomotive force exerted

Coil design

can be extremely large, and if proper bracing is not provided; the coil may gradually work harden and finally fail.

Typical bracing techniques are illustrated in Fig. 2. In Fig. 2a, brass studs are brazed to every other turn. These studs are then secured to insulator posts to hold them in a fixed relation to each other. Nuts on each side of the stud at the insulator allow adjustment for characterization of the heating pattern. In Fig. 2b, the insulation has been contoured to hold the turns relative to each other after the end turns are secured with studs.

The insulation used for bracing applications must meet the criteria for the coil design. In addition to the installation being capable of withstanding the heat radiated from the workpiece, its electrical capabilities must permit it to with-stand the volt- age between the mounting studs or the turn-to-turn voltages of the coil. This is of particular concern when using high-voltage RF coils where up to 12,000v may be impressed across the total coil. It may be necessary in these instances to provide slots between the stud locations in the insu- lator boards to increase the electrical creepage path between the studs. It may also be necessary to increase the heat-resistant characteristics of the insulation by facing the area exposed to the heated surface with a sheet of high-temperature insulation.

For purposes of rigidity, clean-

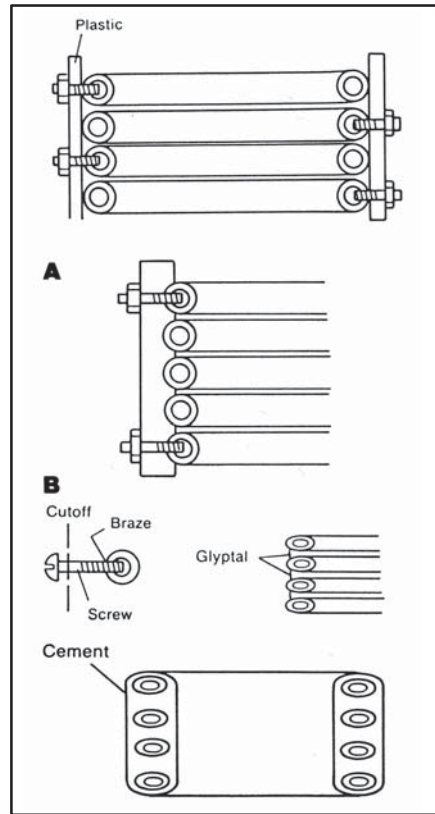

Fig. 2: Typical techniques for bracing of induction-coil turns (from F.W. Curtis, *High Frequency Induction Heating*, McGraw-Hill, New York, 1950)

ness, and protection, it is sometimes desirable to encapsulate work coils in a plastic or refractory material. The same kind of care with respect to voltage and temperature characteristics must be taken with these materials as with insulating boards. For low-temperature induction heating applications, epoxy encapsulation of the coil is quite common. For heating of steel billets, coils are usually cast in a refractory cement to prevent scale from the part from falling between the

turns. In coating of coils with refractory materials, care must be taken to match the pH of the refractory to that of the material being heated; for example, an acidic refractory is required for the ferrous scale that drops off during high-temperature heating of steels.

Design considerations

All coils represent an inductance to the tank circuit. However, in practice, the working portion of the coil may in fact be only a small portion of the inductance presented to the tank. Between the output terminals of the generator or heat station and the heating portion of the work coil, there may be a considerable distance of output lead. In any case, some finite distance exists between the heat-station terminations and the actual coil. Design and construction of these work-coil leads can be a major factor in determining job feasibility.

The effect of lead construction on system performance can be best understood with respect to the tank circuit of which it is a part (Fig. 3). The coil/load inductance is represented by L_2 . Each lead connecting the tank capacitor to the coil has its own inductance (L_1, L_3). If the voltage in the tank, ET, is impressed across the total of these inductances, then some voltage drop appears across each. The full voltage will thus never appear across the work coil. If the inductance of the coil (L_2) is approximately 10 times the total inductance of the leads (L_1 plus L_3) or greater, a maximum of 10% of the total voltage will be lost in the leads. Any loss less than this can be considered nominal.

Some coils have many turns, a large cross-sectional area, and thus fairly high inductance. Hence, the comparative lead inductance is small. As the frequency increases, coils often become smaller in size, and their inductance and inductive reactance decrease. As the distance between the heat station and coil increases, therefore, these lead inductances can become critical.

Several coil designs that illustrate the effect of lead design are shown in Figs. 4 and 5. In Fig. 4a, a coil with leads far apart is depicted. The space between the leads presents an induc-

Frequency	Theoretical wall thickness (= 2 X reference depth (a), mm (in.))	Typical wall thickness available, mm (in.)	Minimum tube diameter (b), mm (in.)
60 Hz	16.80 (0.662)	14.00 (0.550)	42.00 (1.655)
180 Hz	9.70 (0.382)	8.13 (0.320)	24.30(0.955)
540 Hz	5.59 (0.220)	4.67 (0.184)	14.00 (0.550)
1 kHz	4.11 (0.162)	3.43 (0.135)	10.30 (0.405)
3 kHz	2.39 (0.094)	1.98 (0.078)	5.97 (0.235)
10 kHz	1.32 (0.052)	1.07 (0.042)	3.30 (0.130)
450 kHz	0.15 (0.006)	0.89 (0.035)	0.38 (0.015)
1 MHz	0.08 (0.003)	0.89 (0.035)	0.19 (0.0075)

(a) Resistivity of copper assumed to be $1.67 \times 10^{-6} \Omega \cdot \text{cm}$ ($0.66 \times 10^{-6} \Omega \cdot \text{in.}$). (b) Tube ID requirements for adequate cooling-water flow should also be considered.

Table I: Selection of copper tubing for induction coils.

tance almost equal to that of the coil. Thus, a major portion of the voltage will not appear in the working area. A better design (Fig. 4b) minimizes this gap and thus improves heating efficiency. Fig. 5b also shows single-turn, multiplace coils with an extremely poor and an improved lead design.

Another factor to consider is the interaction of the leads with nearby metal structures. Because all leads have some inductance, they can act as work coils. Thus, a conductor placed within their field will be heated. Leads placed adjacent to metal structures will tend to heat them. In addition to unwanted heat, this loss reduces the power available to the load. It is important that lead-to-lead separation be minimized and proximity to metallic structural members be considered. Whenever possible, duct housings, trays, or conduits must be of low-resistivity or insulating materials, such as aluminum or plastic.

Typical lead design

Induction heating lead designs typically make use of water-cooled copper plates or tubes.

When coil voltages are low (~800v), a low-inductance structure known as a fishtail is often utilized. A fishtail is a pair of parallel copper plates that are water cooled to maintain low resistivity. They are placed with their wide bus faces parallel, and are either separated physically with air as an insulator or held together by nylon bolts and nuts with teflon or a similar material acting as a spacer. Extending from the heat station to a point as close as possible to the operating area of the work coil, they present minimum inductance and provide maximum power at the coil. Depending on conditions and construction, efficient runs of up to 15 feet are practical. The thickness of the copper plates should be consistent with the frequency, as noted in Table I, and cooling-water paths and sizes must be consistent with the power being transmitted as well. The copper plates should increase in width with generator power and the distance of the run. Moreover, they should be spaced as close together as possible

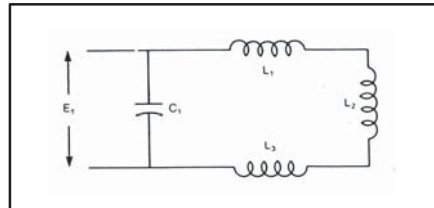

Fig. 3: Schematic circuit diagram indicating the inductance of the coil leads and induction coil itself: L_1, L_3 -lead inductances; L_2 -induction-coil inductance; C_1 -tank capacitance; E_1 -tank voltage

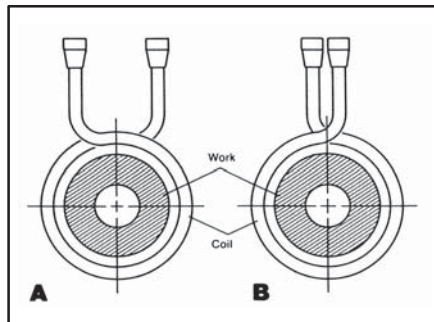

Fig. 4: Effect of coil-lead spacing on lead inductance; closer spacing, as in (b), reduces lead inductance and thus power losses (from F.W. Curtis, *High Frequency Induction Heating*, McGraw-Hill, New York, 1950)

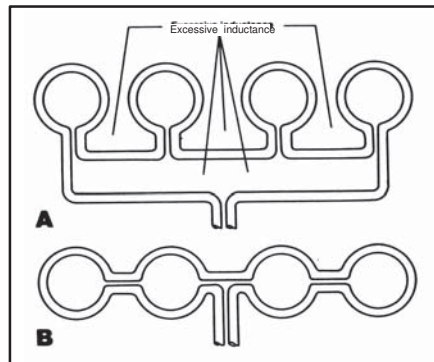

Fig. 5: Lead construction for multiplace inductors; lead design in (b) is preferable because of lower heat inductance (from F.W. Curtis, *High Frequency Induction Heating*, McGraw-Hill, New York, 1950)

with only enough space for proper insulation to prevent arcing.

As the coil inductance increases (e.g., as the number of turns or the coil diameter increases), lead length becomes less critical, and plain copper tubing leads then become more practical. However, larger coils also require higher terminal voltages. These leads must also be kept as close as possible to each other while maintaining sufficient spacing to prevent arcing. However, good practice still dictates that coil leads be kept to a minimum length and

that copper tubing sizes be used that are consistent with frequency, current, and cooling requirements.

Rigid leads, whether tubing or bus, built to the above guidelines are inherently more effective than flexible, water-cooled cable. In some cases, however, it is absolutely necessary to use flexible connections. There are several variations in flexible leads, but it must be kept in mind that the inductive lead losses in flexible cables are usually much greater than those for rigid connections. The most common flexible lead is generally used in applications similar to tilt-type induction melting furnaces and consists of a water-cooled, spiral-wound inner conductor (similar to BX cable, but made of copper) with an outer insulating covering. These leads are used in pairs with one for each lead connection. Not only must they be sized for current and frequency, but the insulation must be capable of handling the voltage rating of the system. Flexible leads should be tied together with insulating straps.

Coaxial leads are also available and may be rigid or flexible. They consist of an inner conductor and an outer sheath or housing that is also used as the return conductor. This outer sheath is generally at ground potential. In addition to providing an extremely low-inductance lead, the outer ground acts to eliminate possible strong radiation or inductive coupling to adjacent structures.

Rigid coaxial lead is generally quite expensive and is usually limited to those applications where it is imperative to transmit high power at high frequency over some distance.

Another type of coaxial cable is the water-cooled type generally used at radio frequencies. It consists of a low-inductance, braided inner conductor that runs through a water-cooled tube, and an outer return braid that is also water cooled. This construction is generally utilized with medium-to-high-inductance coils because its construction does not greatly minimize lead inductance but does provide flexibility. This last type of lead is most common when the operator must physically move the coil from part to part as in bottle sealing.